

DCOM-NEVA

DUAL SERVE / GRAB&GO FREEZER (REMOTE)

Standard features

- Remote Refrigeration
- Stainless Steel interiors for both serve-over and self service
- Thermostat Electronic Control
- Double Glazed Side Wall Right/Left
- LED Lights
- Externally Equalized TXV
- Black or White Painted Outside
- Wellington ERC2 Electronic Fan Motor
- Stainless Steel Bottom Floor and Fan Cover
- Electrostatic Powdered Paint For Exterior



Dimensions

Depth (52")	DCOM-NEVA-6	DCOM-NEVA-8	DCOM-NEVA-12
Length (inches)	74"	98 ½"	147 ½"
Depth (inches)	52"	52"	52"
Amperage	6A	8A	12A
Power	220V 1PH 60HZ	220V 1PH 60HZ	220V 1PH 60HZ
Evaporating Temp	-10C	-10C	-10C
BTU/FT	728	728	728

Technical Drawings

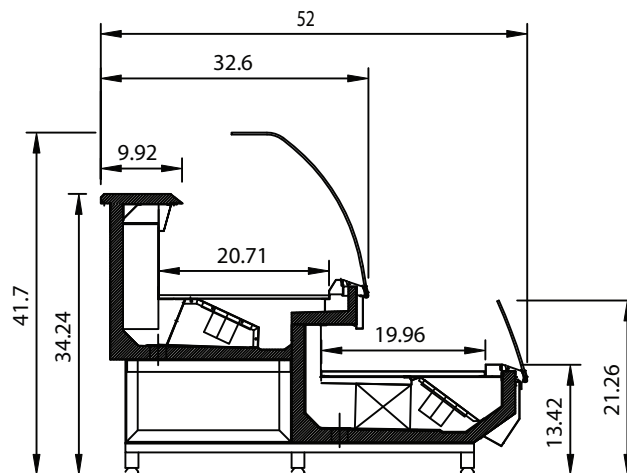

* All measurements are approximates; * Specifications are subject to change without notice; * All equipment are designed to operate in a controlled environment below 75°F (+24°C) temperature and HR 55% relative humidity;