

## PCCG3SR

3 Shelf

### HIGH PROFILE OPENABLE FRONT GLASS REFRIGERATED PASTRY CASE



#### Standard Features

- Internal cooling aggregate
- Dynamic cooling (ventilated) system
- Ecological polyurethane foam insulation
- Back sliding doors with combined glass
- Openable front glass with bending radius R20
- Front glass warm air blast
- Each shelf includes LED lighting
- Leveling legs
- Automatic defrost system
- Automatic condenser vaporization system
- Electronic temperature controller with digital display
- Glass shelves with height and angle adjustment

#### Options

- Multiple colours available
- Option of multiplexing
- Internal frame available in silver or gold
- Remote compressor

#### Metal element colours

- Black, White or Stainless Steel
- Other colors available upon request

#### Technical Drawing

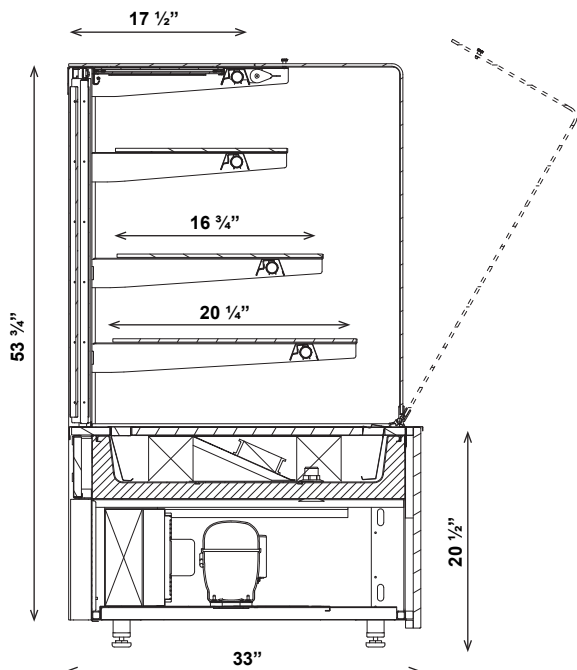

\*\*\*All equipment are designed to operate in a controlled environment below 75°F (+24°C) temperature and HR 55% relative humidity.

#### Dimensions

Model	Dimension W x D x H	Weight (lbs / kg)
PCCG3SR2	24" x 33" x 53 3/4"	
PCCG3SR3	36" x 33" x 53 3/4"	
PCCG3SR4	51 1/2" x 33" x 53 3/4"	
PCCG3SR6	71 1/2" x 33" x 53 3/4"	

\* Customizable options available

\* Multiple sizes available

#### Voltage

- PCCG3SR2,3 :115V / 1ph / 60 Hz / 8A, max. fuse: 15A
- PCCG3SR4 : 115V / 1ph / 60 Hz / 12A, max. fuse: 15A
- PCCG3SR6 : 115V / 1ph / 60 Hz / 15A, max. fuse: 20A

\* Specifications are subject to change without notice.

\*\*All measurements are approximates.