

OM-VOLGA-FV

OPEN MERCHANDISER- FRUIT AND VEGE (REMOTE)

Standard features

- Remote Open Merchandiser
- 2 rows shelves + Base
- Steel Shelves
- Externally Equalized TXV
- Thermostat Electronic Control
- Manual Night Curtain
- Price Tag Holder
- PVC labelling Profiles
- Bar led for top canopy and undershelf lighting
- Angled Mirrors On Top Shelf
- Wellington ERC2 electronic fan motor
- Double Glazed Side Wall Left/Right or Solid Side
- Stainless Steel Evaporator Box with Heating Element and Evaporator Cover
- Electrostatic Powdered Paint For Both Interior-Exterior (choice of colors Black or White)



Dimensions

Depth (40 1/2")	OM-VOLGA-FV4	OM-VOLGA-FV6	OM-VOLGA-FV8	OM-VOLGA-FV10	OM-VOLGA-FV12
Length (inches)	49"	74"	98 1/2"	123"	147 1/2"
Depth (inches)	40 1/2"	40 1/2"	40 1/2"	40 1/2"	40 1/2"
Amperage	1A	1A	1A	1A	1A
Power	115V 1PH 60HZ	115V 1PH 60HZ	220V 1PH 60HZ	220V 1PH 60HZ	220V 1PH 60HZ
Evaporating Temp	-5C	-5C	-5C	-5C	-5C
BTU/FT	1113	1113	1113	1113	1113

Technical Drawings

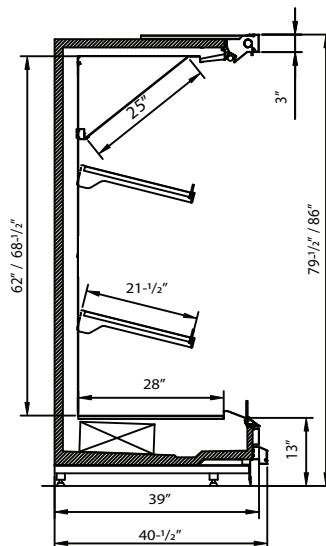

* All measurements are approximates; * Specifications are subject to change without notice; * All equipment are designed to operate in a controlled environment below 75°F (+24°C) temperature and HR 55% relative humidity;